

**IPSC CANADA**

**Pistol Caliber Carbine**

**NATIONALS**



Stage #1 Range 1 Long

Targets: 20 IPSC Targets

Rounds to be Scored :40

Start Position: In Area "A"

Time Starts: On Audible Signal

Procedure: Upon Signal, engage Targets

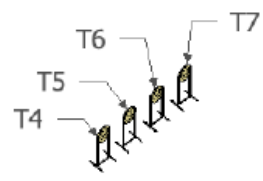
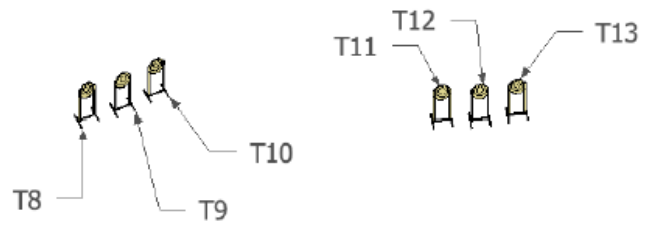

stage 1

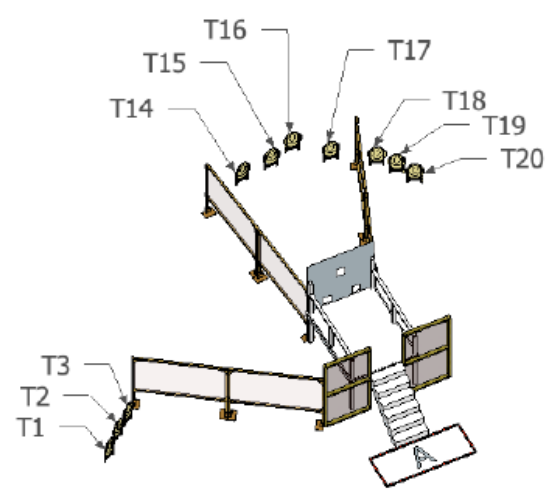

Stage #2 Range 1 Short

Targets: 10 IPSC Mini Poppers

Rounds to be Scored :10

Start Position: In Area "A"

Gun Condition: Gun Loaded ,laying flat ,x mark visible thru trigger Guard

Time Starts: On Audible Signal

Procedure: Upon Signal, engage Targets

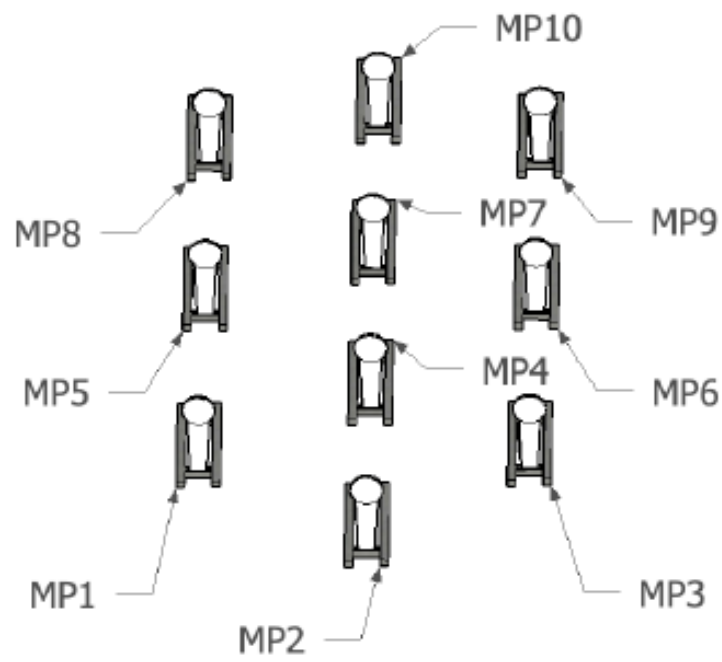

## Stage 2

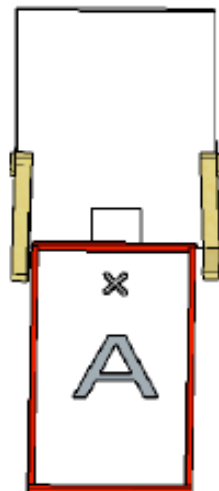

Stage #3 Range 2 Medium

Targets: 12 IPSC Targets

Rounds to be Scored :24

Start Position: In Area "A"

Time Starts: On Audible Signal

Procedure: Upon Signal, engage Targets

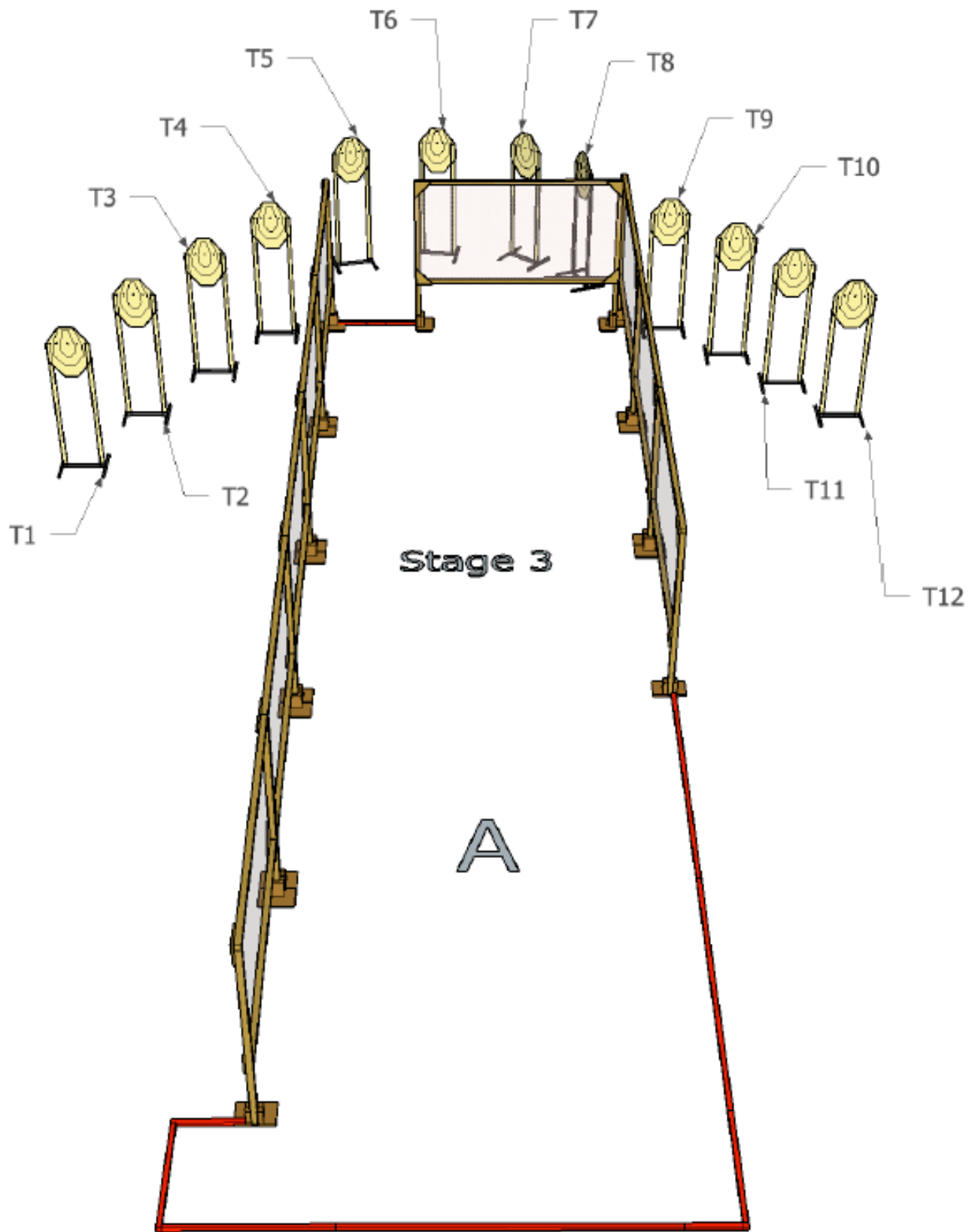



Stage #4 Range 2 Short

Targets: 3 IPSC Mini Targets and 3 IPSC Mini Poppers

Rounds to be Scored :9

Start Position: In Area "A"

Time Starts: On Audible Signal

Procedure: Upon Signal, engage Targets Note Mini Popper 1 activates Mini Target 1, Mini Popper 2 activates Mini Target 2, Mini Popper 3 activates Mini Target 3

All Targets will remain Visible at rest.

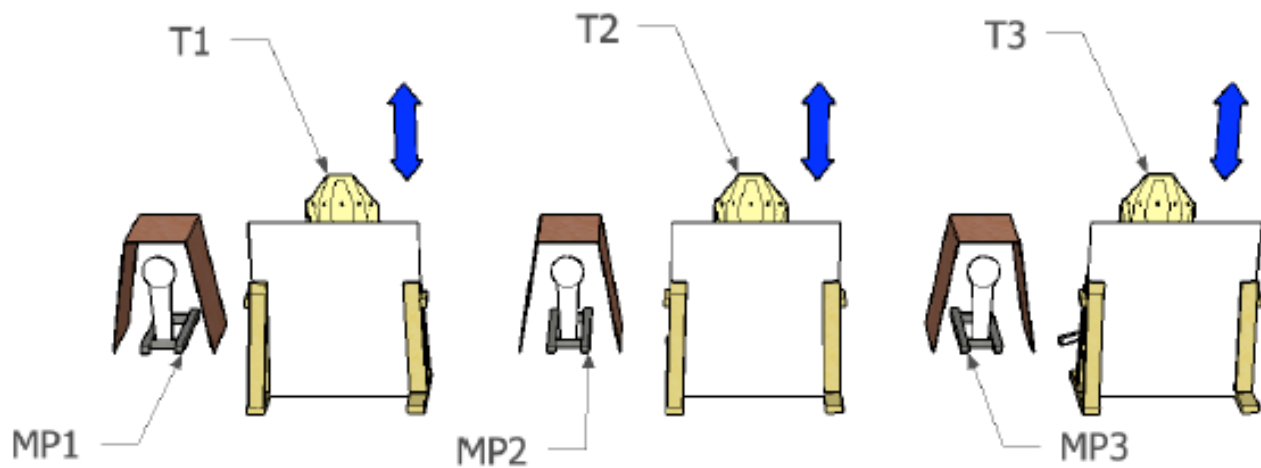

**Stage 4**



Stage #5 Range 3 Medium

Targets: 12 IPSC Targets

Rounds to be Scored :24

Start Position: In Area "A"

Time Starts: On Audible Signal

Procedure: Upon Signal, engage Targets ,Note Right  
Stomp pad Activates Target 10 and Left Stomp pad  
Activates Target 3

Targets will remain Visible at Rest

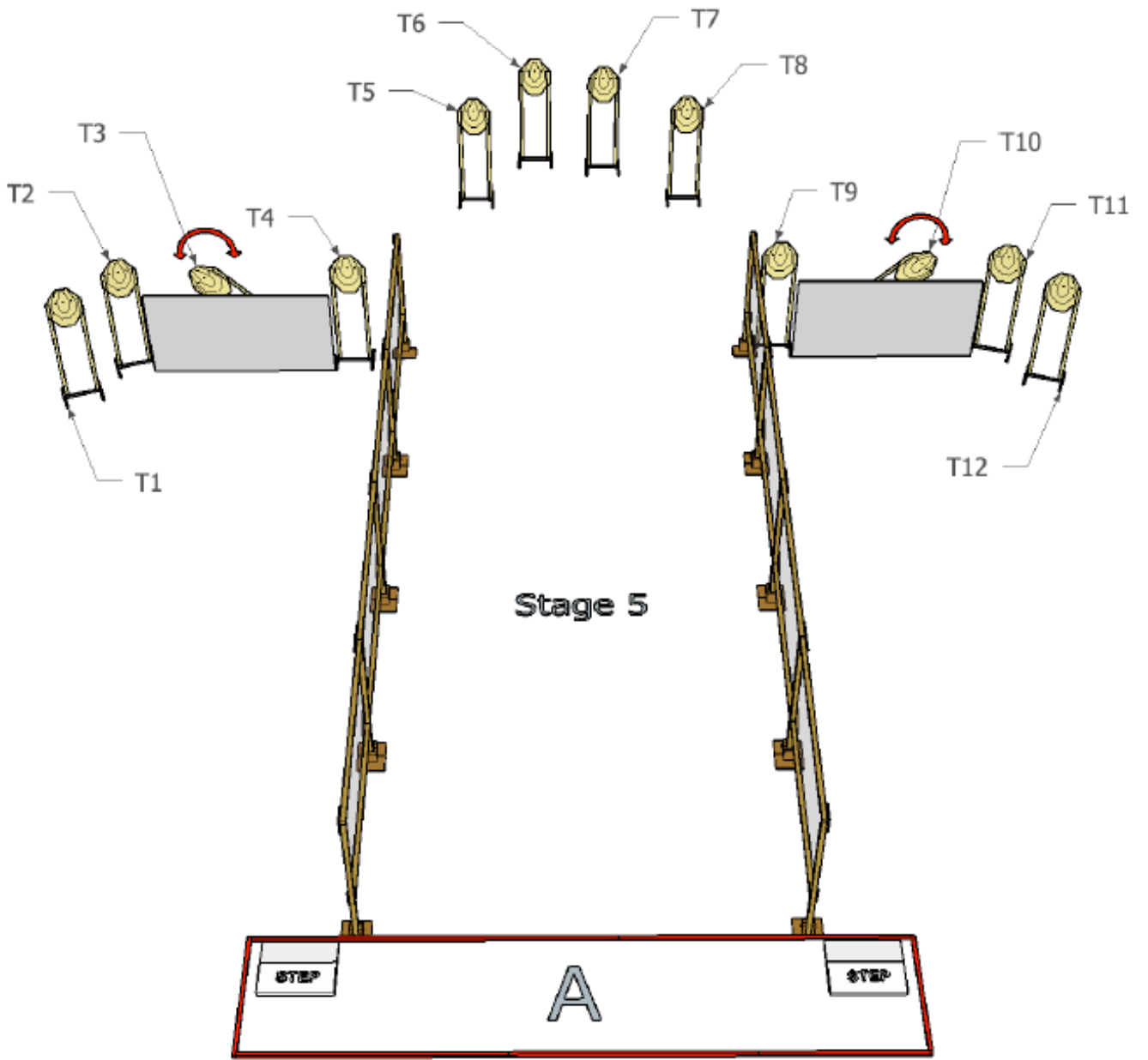

Stage #6 Range 3 Short

Targets: 6 IPSC Targets

Rounds to be Scored :12

Start Position: In Area "A"

Time Starts: On Audible Signal

Procedure: Upon Signal, engage Targets

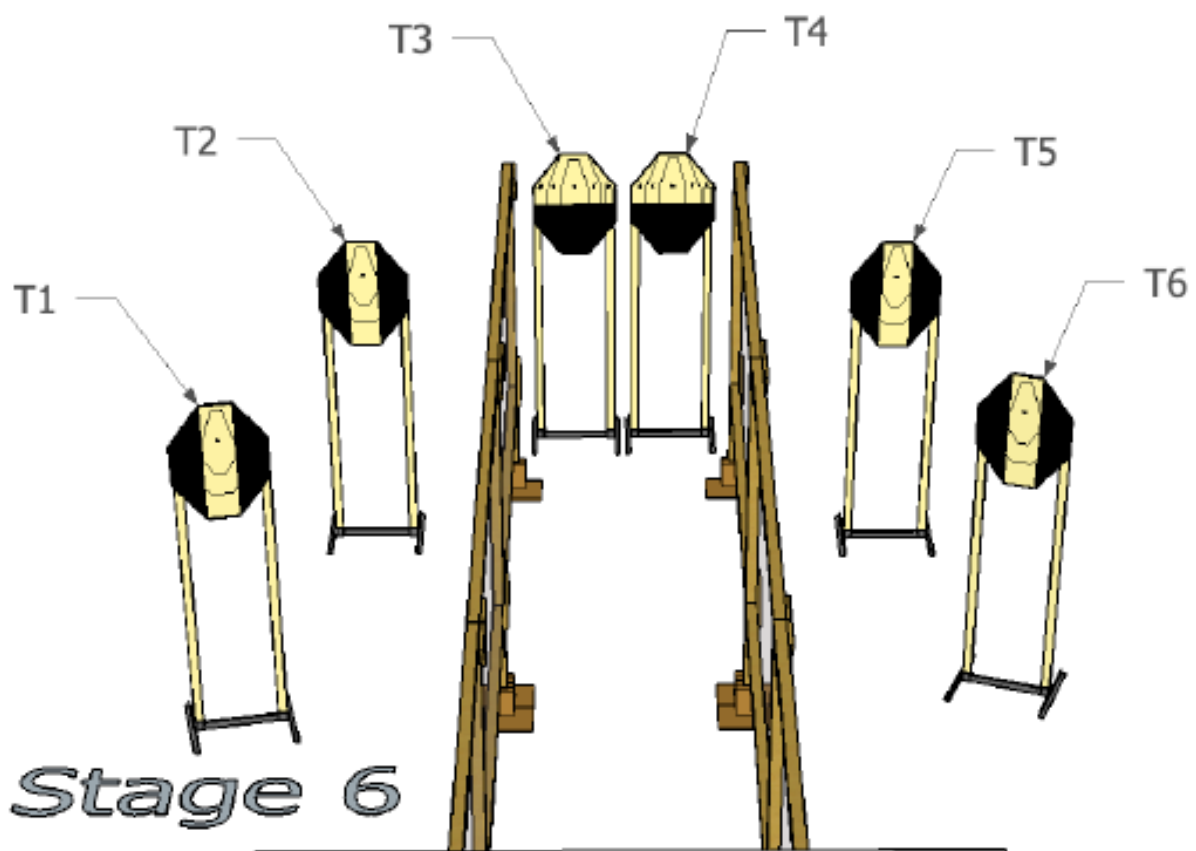

*Stage 6*

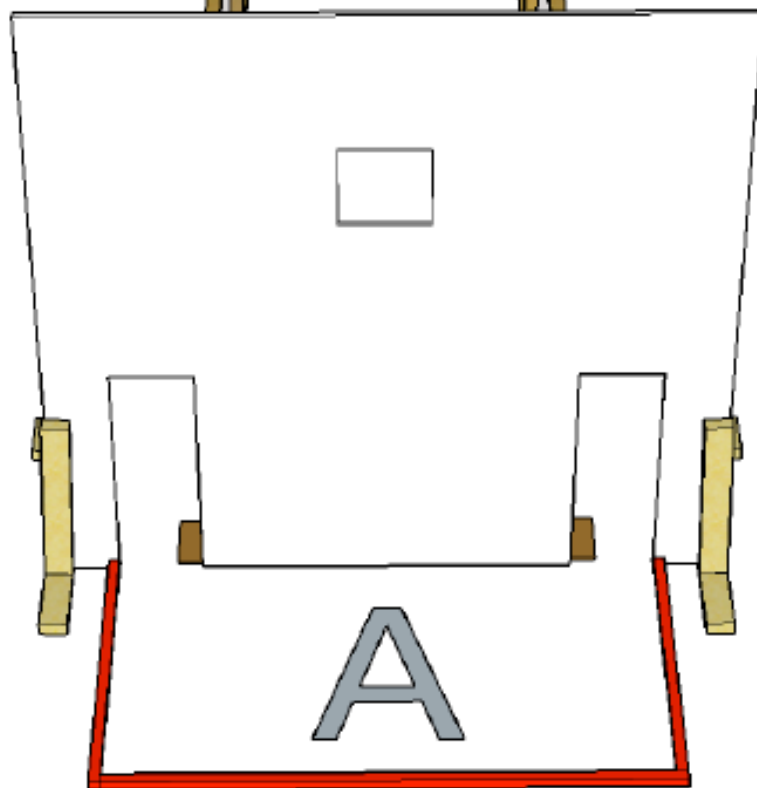

Stage #7 Range 2 Short

Targets: 3 IPSC Targets and 3 IPSC Poppers

Rounds to be Scored :9

Start Position: In Area "A"

Time Starts: On Audible Signal

Procedure: Upon Signal, engage Targets ,Note Popper 2  
activates swinging targets 1,2 and 3

Targets will remain Visible at Rest

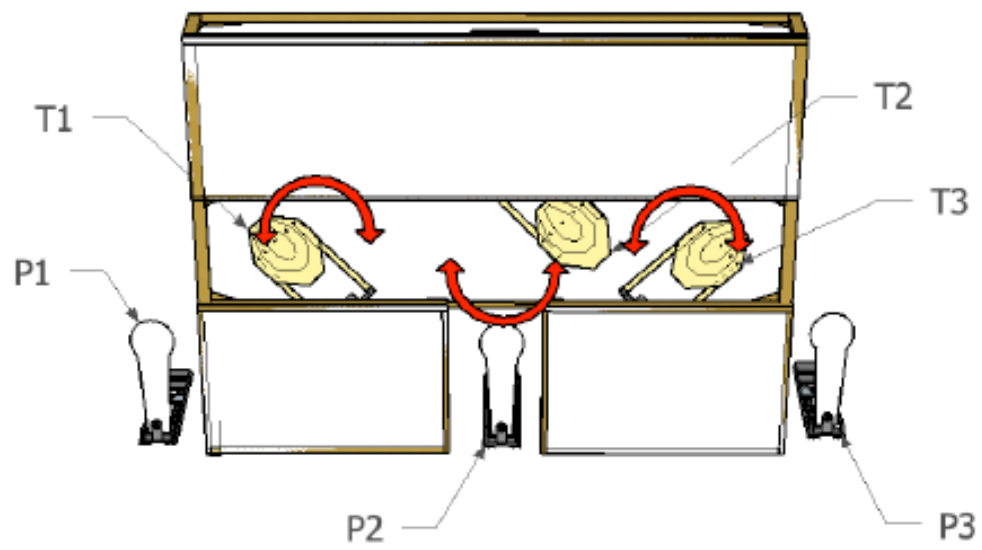

Stage 7





Stage #8 Range 4 Medium

Targets: 12 IPSC Targets

Rounds to be Scored :24

Start Position: In Area "A"

Time Starts: On Audible Signal

Procedure: Upon Signal, engage Targets

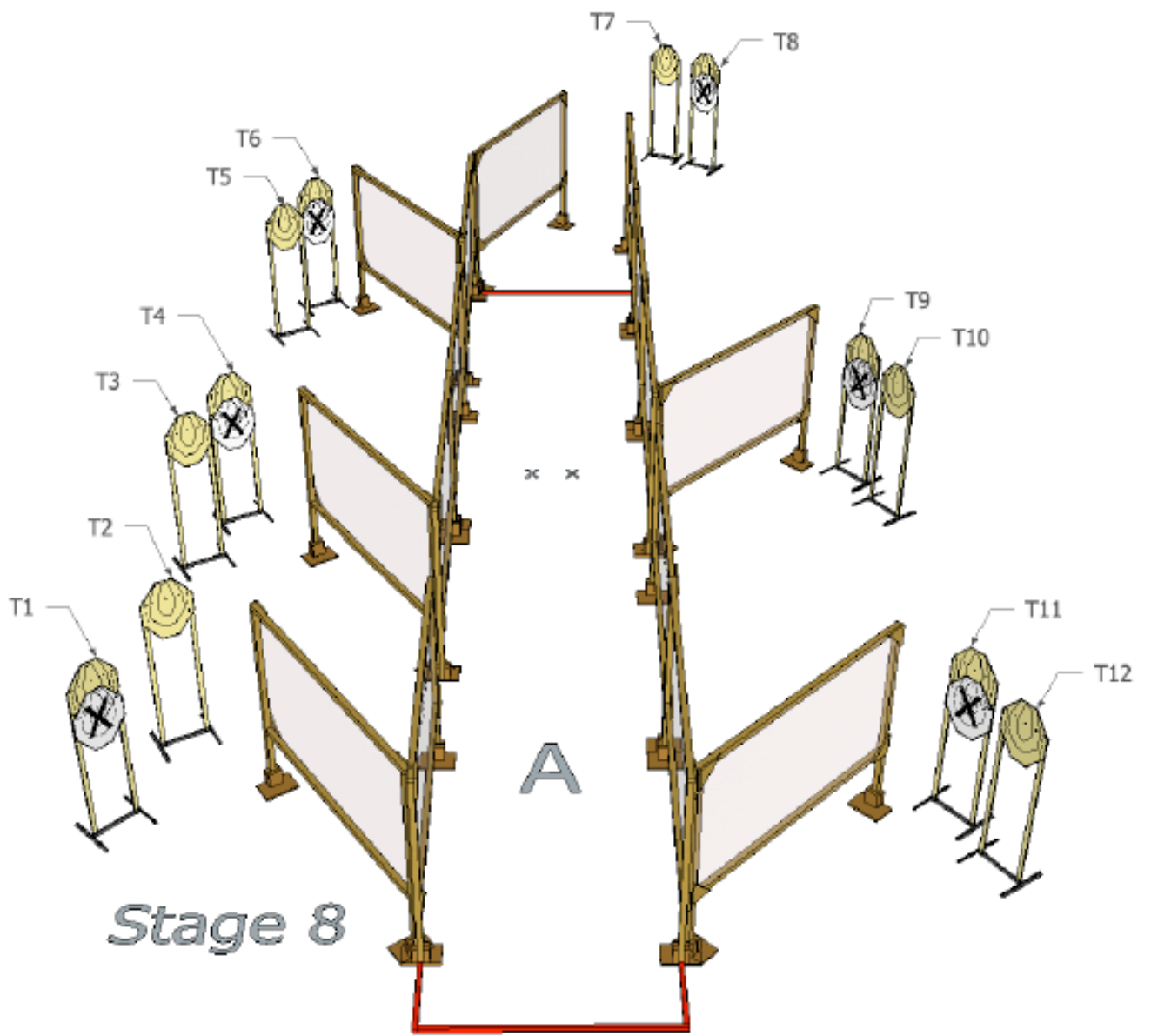

Stage #9 Range 5 Medium

Targets: 9 IPSC Targets and 3 IPSC Poppers

Rounds to be Scored :21

Start Position: In Area "A"

Time Starts: On Audible Signal

Procedure: Upon Signal, engage Targets ,Note Popper 3 activates sliding Targets 1,2 and 3 which are disappearing targets ,Sliding targets 1,2 and 3 will activate appearing targets 7,8 and 9

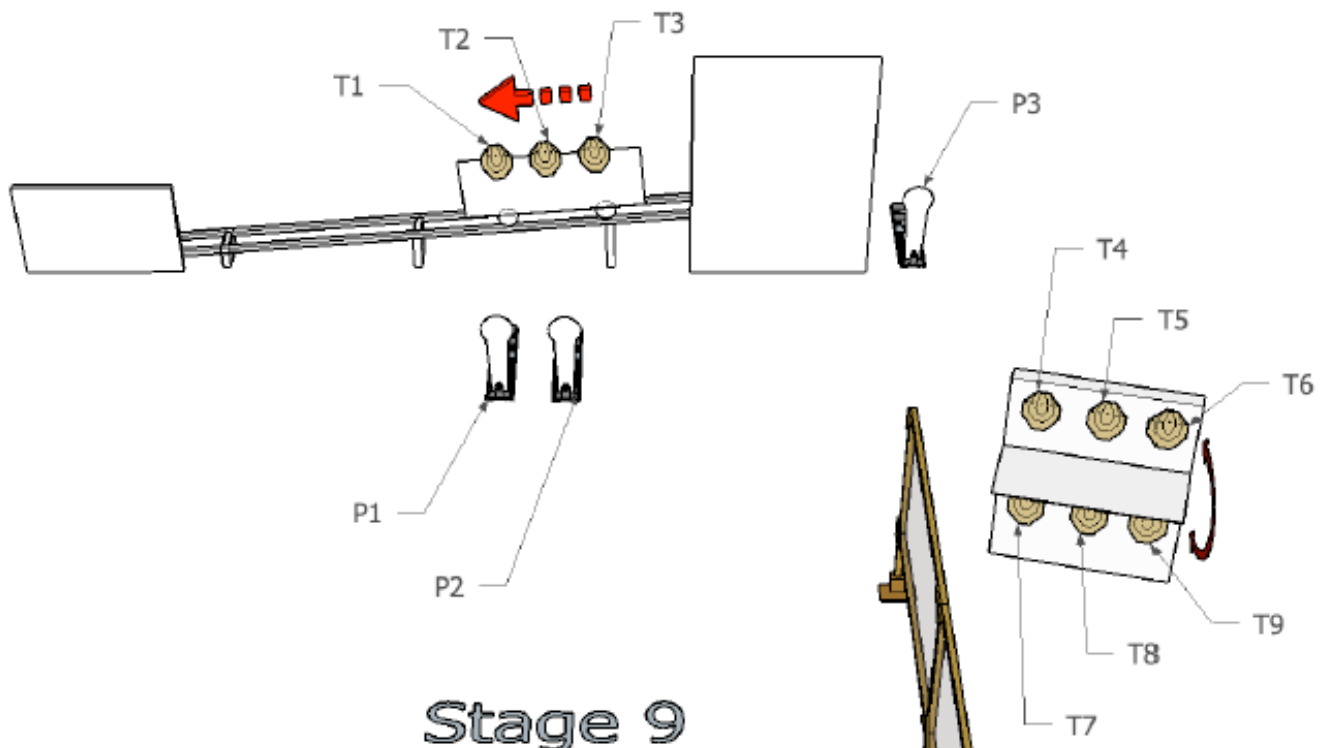

### Stage 9

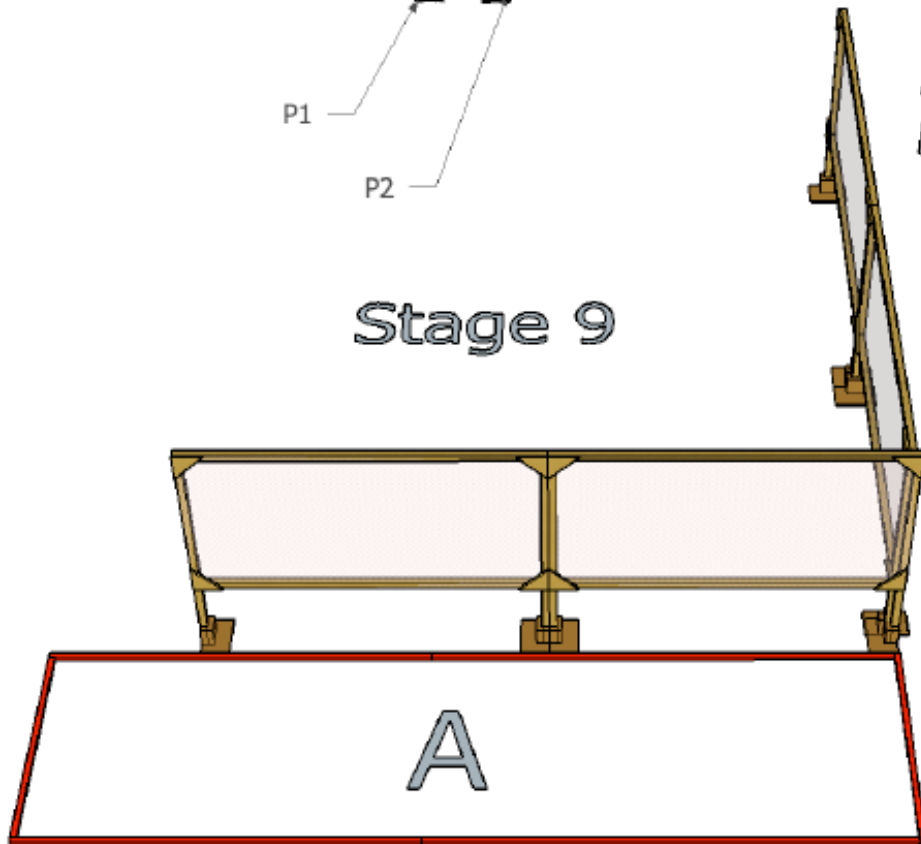

Stage #10 Range 5 Short

Targets: 2 IPSC Targets and 6 IPSC Plates

Rounds to be Scored :10

Start Position: In Area "A"

Time Starts: On Audible Signal

Procedure: Upon Signal, engage Targets

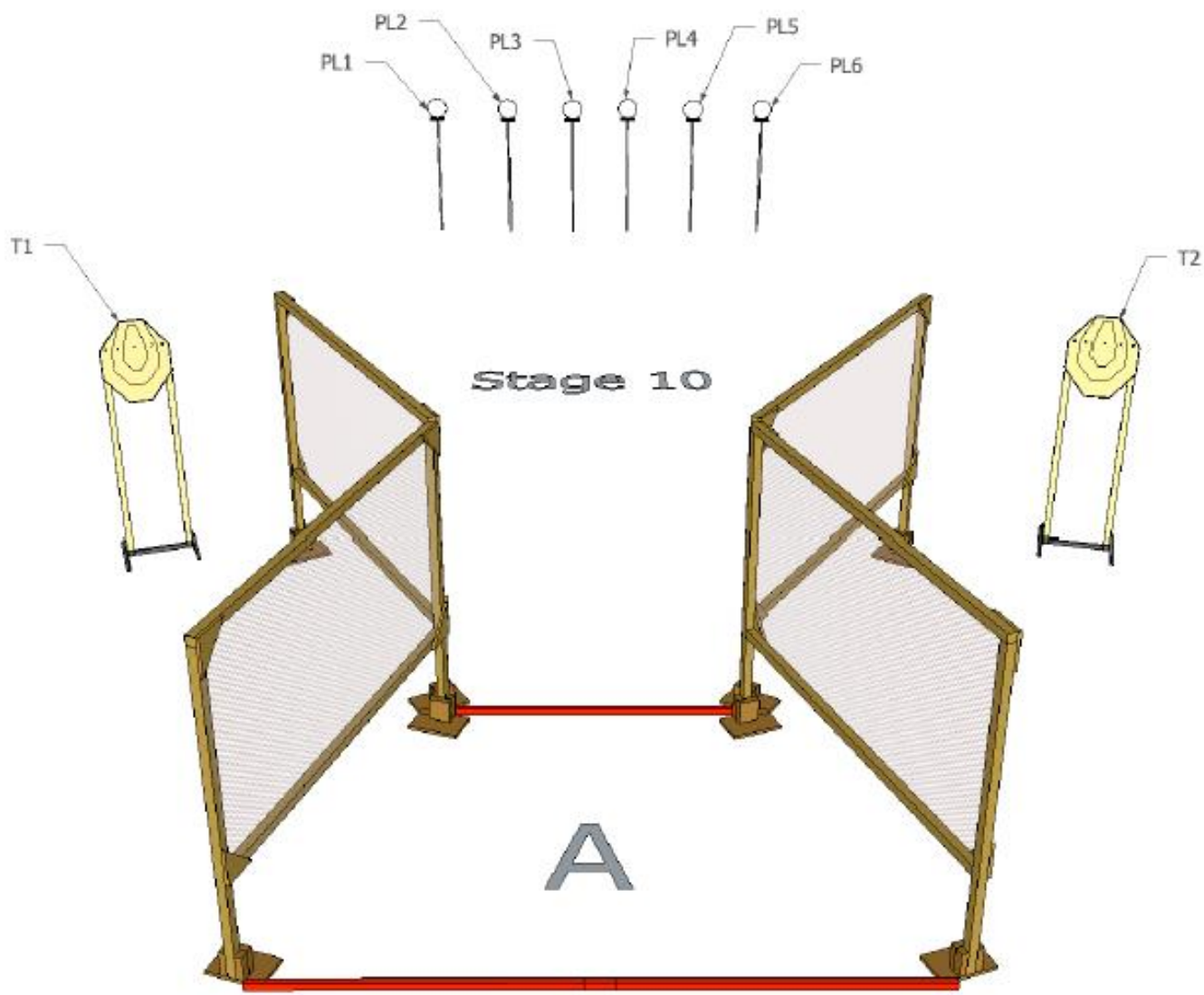

Stage #11 Range 6 Long

Targets: 16 IPSC Targets and 8 IPSC Poppers

Rounds to be Scored :40

Start Position: In Area "A"

Time Starts: On Audible Signal

Procedure: Upon Signal, engage Targets

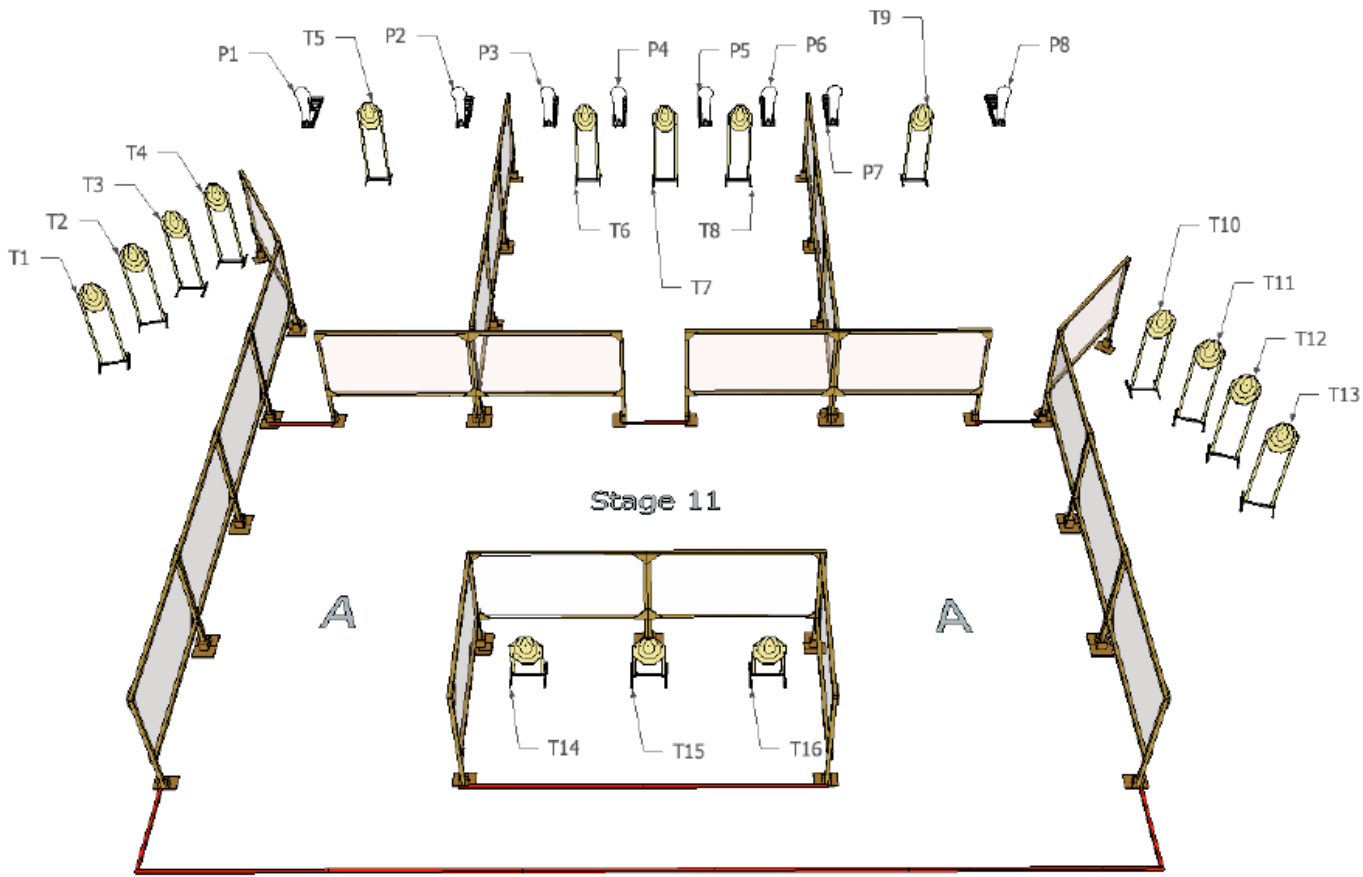



Stage #12 Range 6 Short

Targets: 12 IPSC Micro Targets

Rounds to be Scored :12

Start Position: In Area "A"

Time Starts: On Audible Signal

Procedure: Upon Signal, engage Targets ,best single hit to score

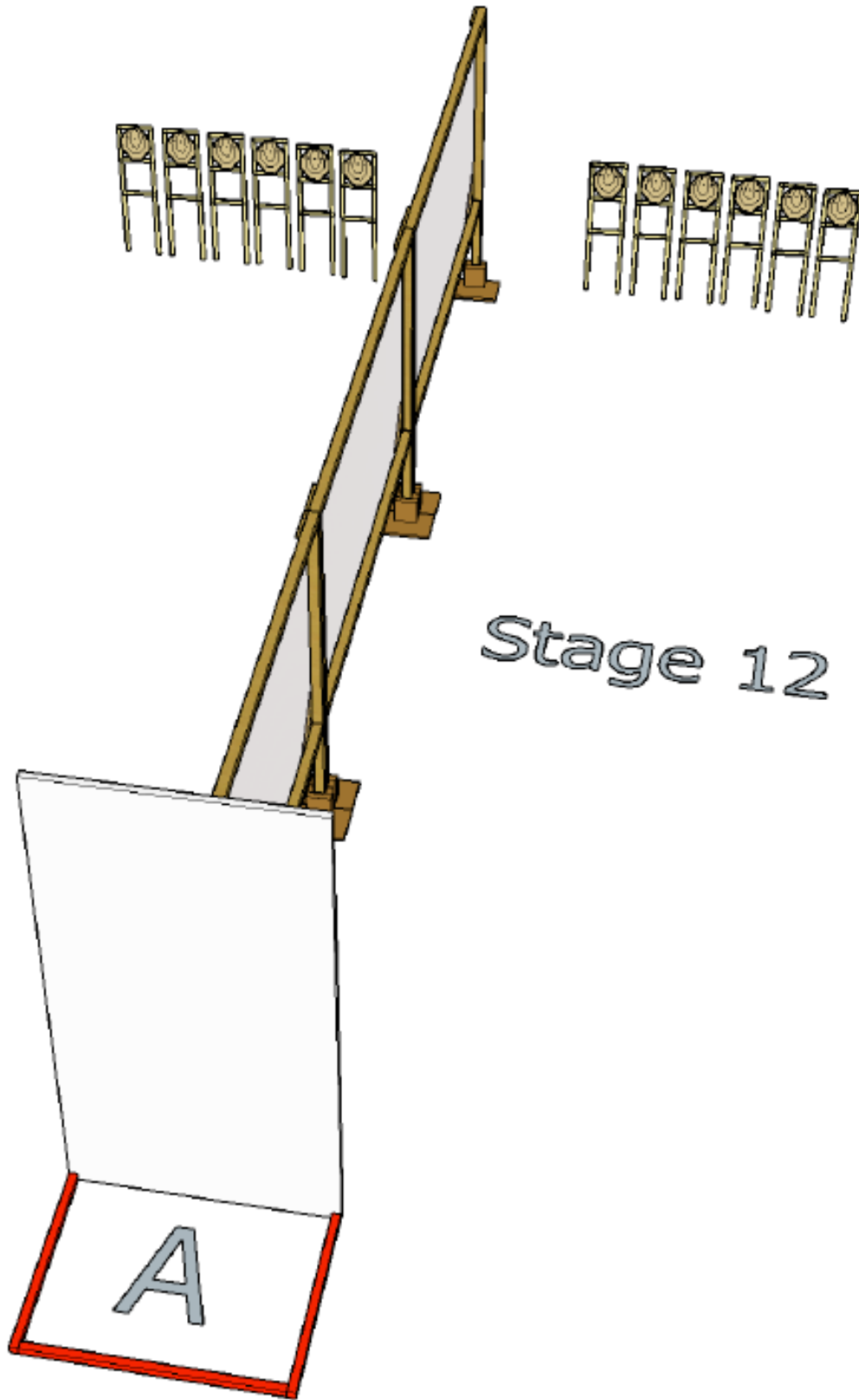

Stage 12

Stage #13 Range 7 Medium

Targets: 10 IPSC Mini Targets

Rounds to be Scored : 20

Start Position: In Area "A"

Time Starts: On Audible Signal

Procedure: Upon Signal, engage Targets

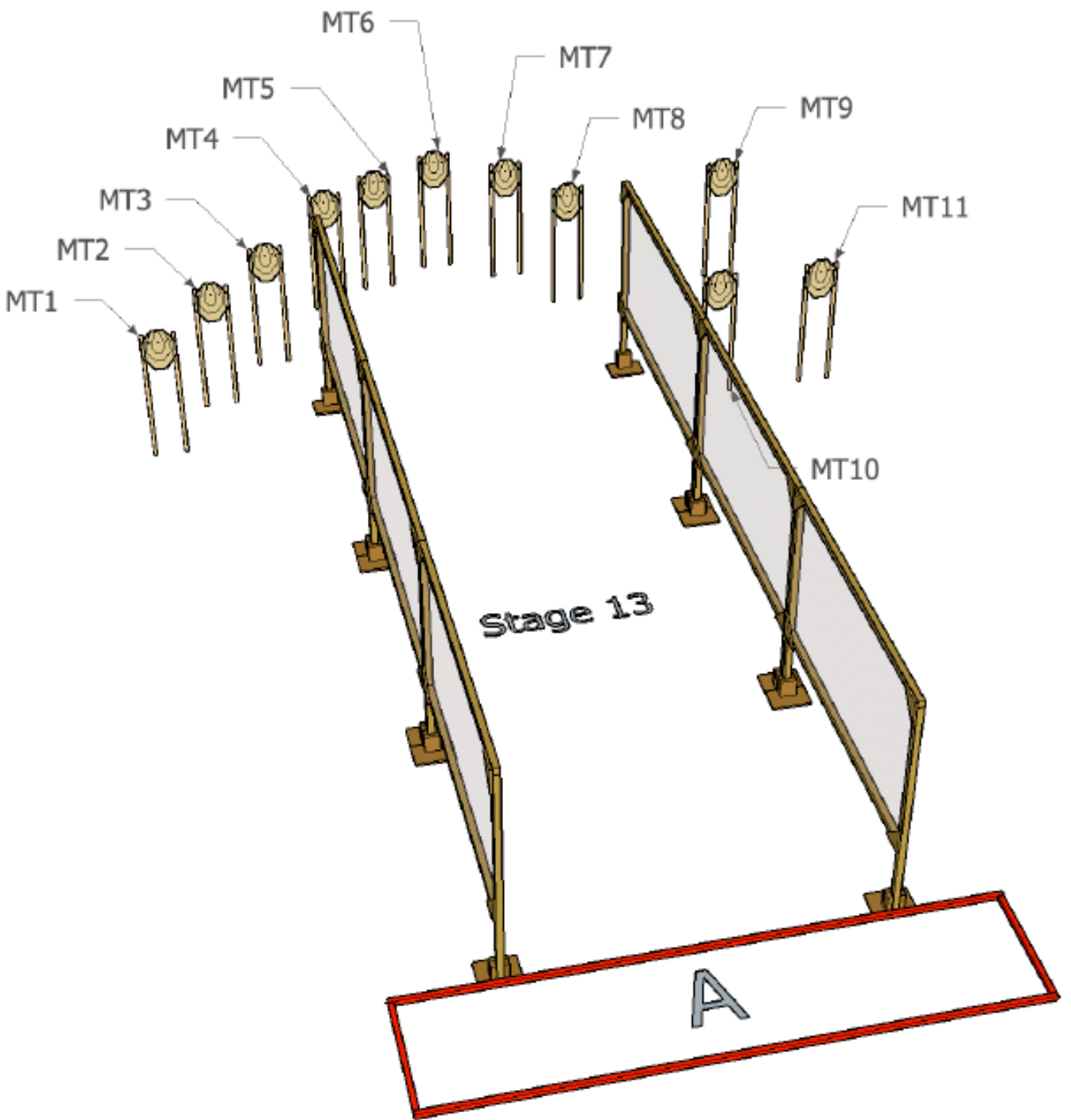

Stage #14 Range 7 Short

Targets: 10 IPSC Poppers

Rounds to be Scored :10

Start Position: In Area "A"

Time Starts: On Audible Signal

Procedure: Upon Signal, engage Targets

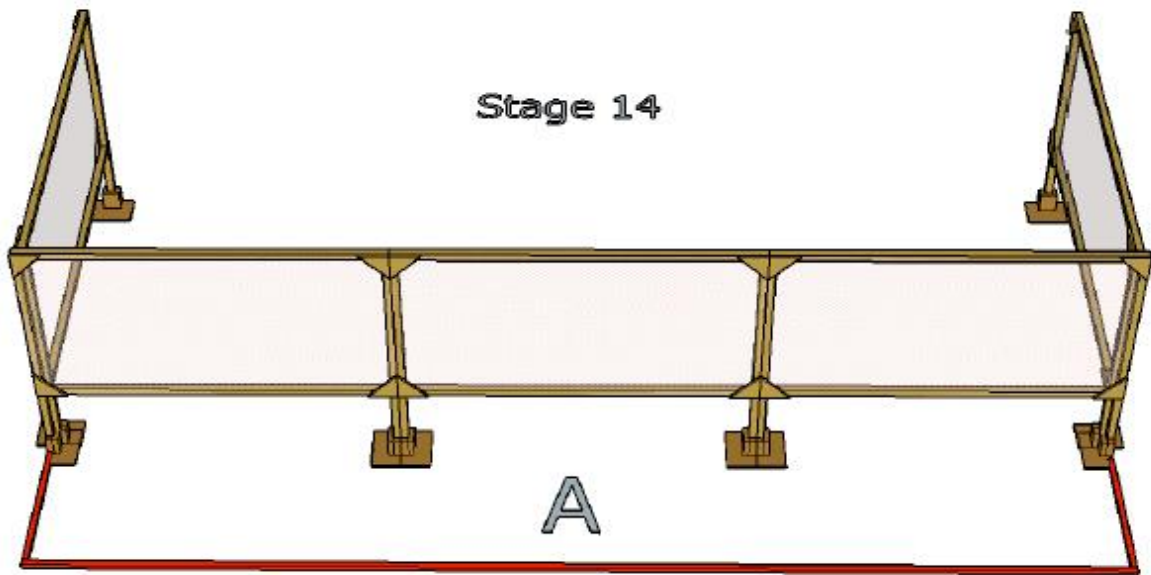
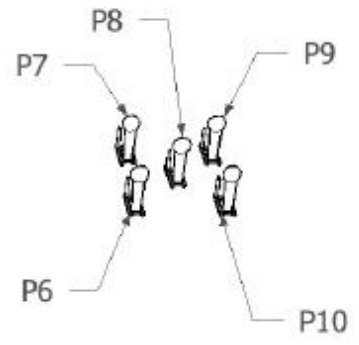
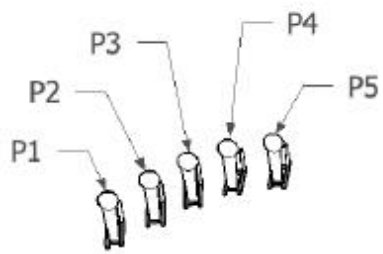

Stage #15 Range 8 Short

Targets: 3 IPSC Targets and 4 IPSC Poppers

Rounds to be Scored :10

Start Position: In Area "A"

Time Starts: On Audible Signal

Procedure: Upon Signal, engage Targets

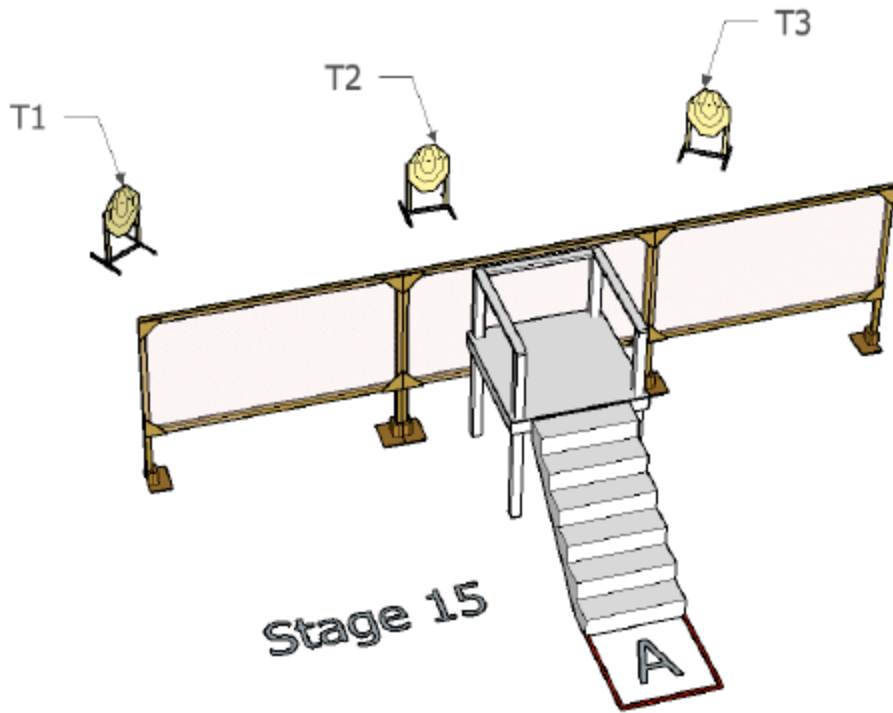



Stage #16 Range 8 Medium

Targets: 12 IPSC Targets

Rounds to be Scored :24

Start Position: In Area "A"

Time Starts: On Audible Signal

Procedure: Upon Signal, engage Targets

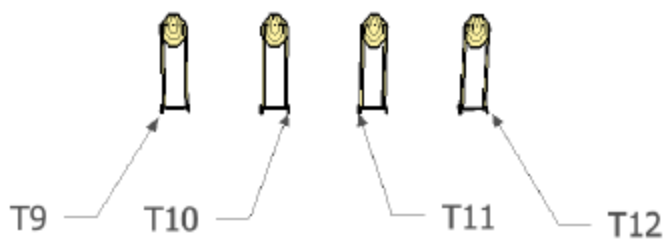

**STAGE 16**



**60 M**

